



RGS Riverdale Gravimetric System



The First **Complete Sealed Delivery System™** for Color and Additives.

Partnered With
MAGUIRE®
Intelligent Simplicity

- ✓ We provide and maintain the RGS Stand. Equipment investment isn't needed.
- ✓ **MAGUIRE®** Gravimetric metering boosts accuracy and economy.
- ✓ Uses **Pump-In-A-Drum®** technology, and remains clean and sealed.
- ✓ **Real-time data** to track color match status, orders, and inventory.
- ✓ **Color delivery tolerance within 0.1%**. No over-coloring, reduces costs, and maintains target color levels.
- ✓ The **RGS** is easy to maintain and clean.
- ✓ **Max throughput capacity: 80 lb/hr (36 kg/hr)**
- ✓ **RGS-5 or RGS-30** options for use with 5 or 30 gallon drums.

ACCURATE

- Automatic versatile speed control to assure self-adjusting accuracy.
- Proven loss-in-weight technology.
- Automatically calibrates.
- Automatic adjustments guarantee.
- Potentiometer detects diaphragm movement to 1/1000th of an inch.
- Dual Load Cells – balanced load readings improve accuracy.
- Extreme accuracy with 1:250,000 scale resolution.
- RGS-5 will detect a tenth of a gram of weight change over a 25,000 gram pail.
- RGS-30 will detect a half of a gram change over a 900,000 gram drum.
- Impervious to large temperature swings.

EFFICIENT

- No tools required for assembly.
- Throat adapter fits readily on most processing machine throats.
- Easy-to-use microprocessor controller saves time.
- User-friendly controller has intuitive setup procedure.
- Reduces input error – simply enter let-down ratio and shot weight or lb/hr.
- Automatically adjusts to screw recovery time and extruder output.
- Eliminates downtime with color change.
- Automatically re-calibrates to new color, so no additional setup is required.
- Save settings / recipe to a thumb drive for faster color / product setup:
 - Plug thumb drive into the RGS pump controller and select the desired color.
- No tube sets to replace – one delivery tube for life of color.
- Lifetime warranty.

CLEAN AND MESS FREE

Sealed Drums

- Drums are sealed. There's no need to open. This seal prevents costly spills and ensures that the color is never contaminated with debris.

Sealed Delivery Tubes

- Sealed delivery tubes guarantee clean, quick disconnects to prevent spillage when changing out drums.

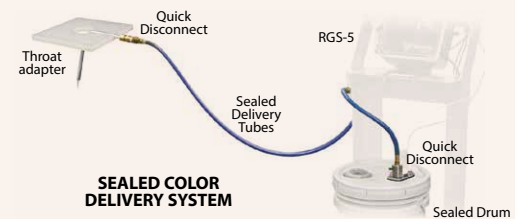

DATA & COMMUNICATIONS

- USB port allows data download, data printout and software update capability.
- Communicates with **MAGUIRE®** Weight Scale Blenders (WSB) to follow regrind usage to prevent over coloring.
- Communicates with **MAGUIRE®** Loss in Weight (LIW) system for extrusion control.
- Communicates with **GlobalTracker™** to track usage and color by work orders, operator IDs, as well as lot numbers.

OPTIONS

- Dual pump options available for very high throughput situations.
- Auto refill options from a tote or drum - No downtime

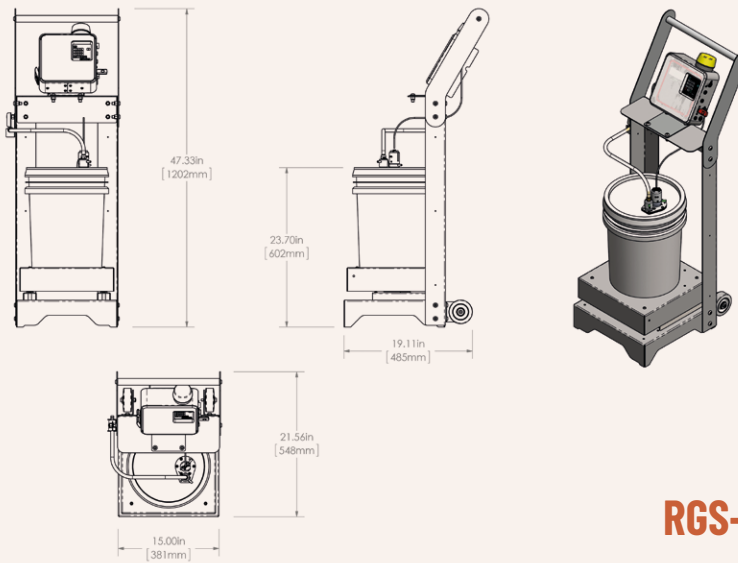
RGS-5

PUMP IN A DRUM® (PIAD)

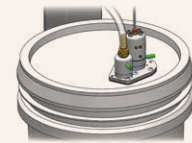

SEALED DELIVERY TUBES

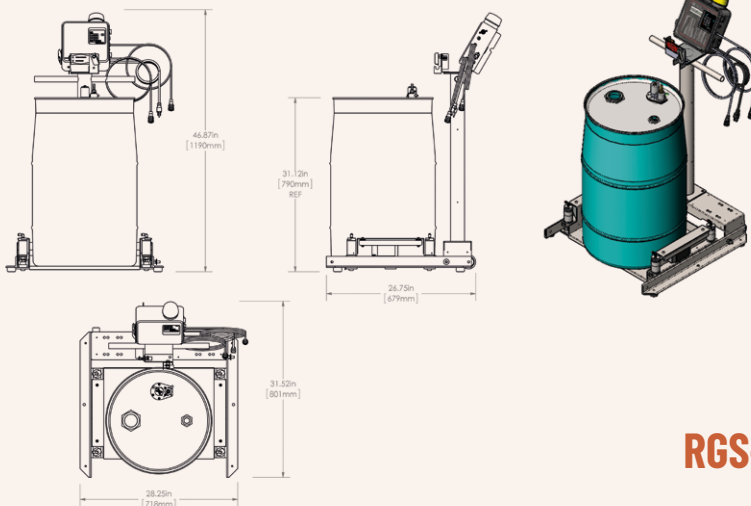
RGS-30

THROAT ADAPTER & SEALED CONNECTION

